

all dimensions in mm.

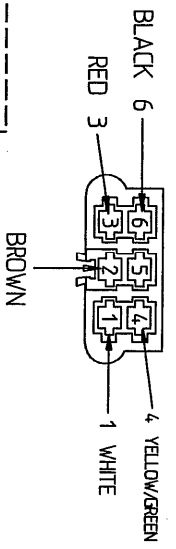
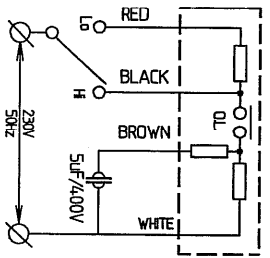
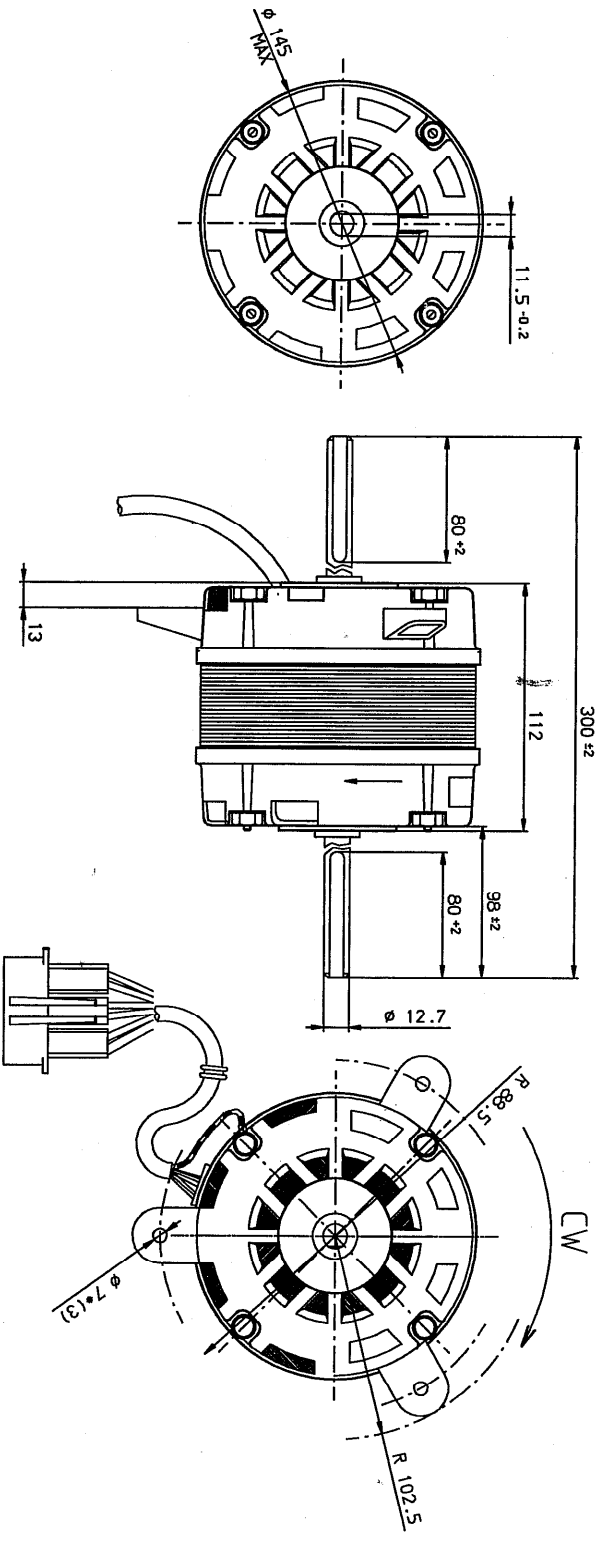

WIRE CAT#	1673367	LEW. WIRE
DESCRIPTION	COLOR	WIRE ENDS
	YELLOW/GREEN	850-50
	WHITE/BLACK	800+50
	RED/BROWN	PN. MALE FASTON 250
LEADS		
Ø2 PVC SLEAVE	BLACK	470-30
105		

print color: RED

TYPE	6383361	TCL-20	DYNAR
PH	230V	50Hz	13A
CL.B	THPR	5µF/400V	HP-1/4
RP	M/930/830		DATE

OLD: 31-229

DRWG NO.	4714	Motor assembly -	TCL-20
Drawn	EL	010703	CatNo: 1313362
Approved			
Scale	1/2	Motor type	6383362
Gen. Tolerance	±10	Customer	TADIRAN
File:	E-GR638-3362/ASSY	VI:	3361
		PRINT:	030703
		CAT. No:	